

DIP 1A

## DIP SW - GHOSTS 'N GOBLINS"

ITEM	DESCRIPTION	1	2	3	4	5	6	7	8
	UNUSED								
DIFFICULTY	EASY		OFF	OFF					
	NORMAL		OFF	ON					
	DIFFICULT		ON	OFF					
	VERY DIFFICULT		ON	ON					
BONUS POINTS	20,000, 70,000 EVERY 70,000				OFF	OFF			
	30,000, 80,000 EVERY 80,000				OFF	ON			
	20,000, 80,000 ONLY				ON	OFF			
	30,000, 80,000 ONLY				ON	ON			
TYPE	TABLE						OFF		
	UPRIGHT						ON		
NUMBER OF PLAYERS	3 PLAYERS						OFF	OFF	
	4 PLAYERS						OFF	ON	
	5 PLAYERS						ON	OFF	
	7 PLAYERS						ON	ON	

DIP 2A

ITEM	DESCRIPTION	1	2	3	4	5	6	7	8
PORTRAIT	NORMAL	OFF							
	REVERSAL	ON							
TEST MODE	NORMAL		OFF						
	TEST		ON						
SOUND	WITH SOUND			ON					
	WITHOUT SOUND			OFF					
COIN MODE	COIN 1 SET UP				OFF				
	COIN 2 SET UP				ON				
COIN	1 COIN / 1 CREDIT					OFF	OFF	OFF	OFF
	1 COIN / 2 CREDITS					OFF	OFF	OFF	ON
	1 COIN / 3 CREDITS					OFF	OFF	ON	OFF
	1 COIN / 4 CREDITS					OFF	OFF	ON	ON
	1 COIN / 5 CREDITS					OFF	ON	OFF	OFF
	1 COIN / 6 CREDITS					OFF	ON	OFF	ON
	1 COIN / 7 CREDITS					OFF	ON	ON	OFF
	2 COINS / 1 CREDIT					OFF	ON	ON	ON
	2 COINS / 2 CREDITS					ON	OFF	OFF	OFF
	2 COINS / 5 CREDITS					ON	OFF	OFF	ON
	3 COINS / 1 CREDIT					ON	OFF	ON	OFF
	3 COINS / 2 CREDITS					ON	OFF	ON	ON
	3 COINS / 4 CREDITS					ON	ON	OFF	OFF
	4 COINS / 1 CREDIT					ON	ON	OFF	ON
	4 COINS / 3 CREDITS					ON	ON	ON	OFF
	FREE PLAY					ON	ON	ON	ON



2-7

G.G.

ITEM	DIP SW A	1	2	3	4	5	6	7	8
COIN2	UNUSED								
	EASY	OFF	OFF						
	NORMAL	OFF	ON						
	DIFFICULT	ON	OFF						
	VERY DIFFICULT	ON	ON						
BONUS	20,000, 70,000 EVERY 70,000	OFF	OFF						
	30,000, 80,000 EVERY 80,000	OFF	ON						
PLAYER	POINTS	20,000, 80,000 ONLY			ON	OFF			
		30,000, 80,000 ONLY			ON	ON			
	TYPE	TABLE					OFF		
		UPRIGHT					ON		
START-SCREEN	NUMBER OF PLAYERS	3 PLAYERS					OFF	OFF	
		4 PLAYERS					OFF	ON	
		5 PLAYERS					ON	OFF	
		7 PLAYERS					ON	ON	

GHOST GOBLIN 2

ITEM	DIP SW P	1	2	3	4	5	6	7	8
PORTRAIT	NORMAL			OFF					
	REVERSE			ON					
TEST	MODE			OFF					
	NORMAL			ON					
SOUND	WITH SOUND			ON					
	WITHOUT SOUND			OFF					
BONUS	COIN MODE					OFF			
	COIN 1 SET UP					ON			
	COIN 2 SET UP								
	1 COIN / 1 CREDITS						OFF	OFF	OFF
	1 COIN / 2 CREDITS						OFF	OFF	ON
	1 COIN / 3 CREDITS						OFF	ON	OFF
	1 COIN / 4 CREDITS						OFF	ON	ON
	1 COIN / 5 CREDITS						OFF	ON	OFF
	1 COIN / 6 CREDITS						OFF	ON	ON
	1 COIN / 7 CREDITS						OFF	ON	ON
COIN	2 COIN / 1 CREDITS						ON	OFF	OFF
	2 COIN / 2 CREDITS						ON	OFF	ON
	2 COIN / 5 CREDITS						ON	OFF	ON
	3 COIN / 1 CREDITS						ON	OFF	ON
	3 COIN / 2 CREDITS						ON	OFF	ON
	3 COIN / 4 CREDITS						ON	ON	OFF
	4 COIN / 1 CREDITS						ON	ON	ON
	4 COIN / 3 CREDITS						ON	ON	ON
	FREE PLAY						ON	ON	ON

4.4

GHOST GOBLIN

85-10-21

SOLID SIDE

PART SIDE

GND	1	GND	1
GND	2	GND	2
+5	3	+5	3
+5	4	+5	4
GREEN	5	RED	5
SYNC	6	BLUE	6
GND	7	GND	7
	8		8
2PSHOT2	9	SHOT2	9
2PSHOT1	10	SHOT1	10
2PUP1	11	UP1	11
2PDOWN1	12	DOWN1	12
2PLEFT1	13	LEFT1	13
2PRIGHT1	14	RIGHT1	14
GND	15	GND	15
2PSELECTOR	16	1PSELECTOR	16
	17		17
COIN2	18	COIN1	18
GND	19	GND	19
	20		20
	21		21
	22		22
	23		23
SPEAKER	24	SPEAKER	24
+12	25	+12	25
GND	26	GND	26
GND	27	GND	27
GND	28	GND	28

GHOSTS N GOBLINS

<u>SOLDER(DOWN)</u>		<u>PART (UP)</u>
GND	1	GND
GND	2	GND
	3	
GREEN	4	RED
SYNC	5	BLUE
	6	
	7	
	8	
	9	SHOOT
	10	SHOOT
	11	UP
	12	DOWN
	13	LEFT
	14	RIGHT
	15	
	16	START
	17	
	18	COIN
	19	
	20	
	21	
	22	
	23	
SOUND	24	
	25	
	26	
	27	
	28	

# GHOSTS & GOBLINS DIP SW

## SWITCH 1 A

1	2	3	4	5	6	7	8	OPTION	
OFF ON								SCREEN NORMAL TURN OVER	
	OFF ON							TEST MODE NORMAL MODE TEST MODE	
		OFF ON						SOUND WITHOUT WITH	
			OFF ON					COIN MODE COIN 1 COIN 2	
				OFF OFF	OFF OFF	OFF OFF	OFF ON	COIN THIS ROTATION IS VARID FOR COIN 1, COIN 2, ONRY BY SWITCH NO 4  FREE PLAY → YOU CAN START GAME WITHOUT CREDIT	
				OFF OFF	OFF OFF	ON ON	OFF ON		1 COIN 1 CREDIT 2
				OFF OFF	OFF OFF	ON ON	OFF ON		3
				OFF OFF	ON ON	OFF OFF	OFF ON		4
				OFF OFF	ON ON	ON ON	OFF ON		5
				OFF OFF	ON ON	ON ON	ON ON		6
				ON ON	OFF OFF	OFF OFF	OFF ON		7
				ON ON	OFF OFF	OFF OFF	ON ON		2 COINS 1
				ON ON	OFF OFF	ON ON	OFF ON		3
				ON ON	OFF OFF	ON ON	ON ON		5
				ON ON	ON ON	OFF OFF	OFF ON	3 COINS 1	
				ON ON	ON ON	ON ON	OFF ON	2	
				ON ON	ON ON	ON ON	ON ON	4	
				ON ON	ON ON	ON ON	ON ON	4 COINS 1	
				ON ON	ON ON	ON ON	ON ON	3	
				ON ON	ON ON	ON ON	ON ON	FREE PLAY	

## SWITCH 2 A

1	2	3	4	5	6	7	8	OPTION
	OFF OFF ON ON	OFF ON OFF ON						DIFFI CULTY VEY EASY EASY DIFFCUT VEY DIFFCUT
			OFF OFF ON ON	OFF ON OFF ON				BONUS SCORE 20,000, 70,000, every 70,000 30,000, 80,000, 80,000 20,000, 80,000 ONLY 30,000, 80,000 ONLY
					OFF ON			UP-RIGHT / TABLE TABLE UP-RIGHT
						OFF OFF ON ON	OFF ON OFF ON	NUMBER OF PLAYER 3 4 5 7



G H O S T   A N D   G O B L I N

			( DIP SW 1 )							
			1	2	3	4	5	6	7	8
GND	1	GND	SCREEN REVERCE	ON						
GND	2	GND	'' NORMAL	OFF						
+5V	3	+5V	TEST MODE		ON					
+5V	4	+5V	NOMAL NODE		OFF					
TV GREEN	5	TV RED	DEMO SOUND			ON				
TV SYNC	6	TV BLUE	NO SOUND			OFF				
GND	7	GND	COIN MODE (coin 1)				OFF			
	8		'' (coin 2)				ON			
2P SHOT2	9	1P SHOT 2	GAME CHARGE							
2P SHOT 1	10	1P SHOT 1	1coin 1credit				OFF	OFF	OFF	OFF
2P UP	11	2P UP	1coin 2credit				OFF	OFF	OFF	ON
2P DOWN	12	1P DOWN	1coin 3credit				OFF	OFF	ON	OFF
2P LEFT	13	1P LEFT	1coin 4credit				OFF	OFF	ON	ON
2P RIGHT	14	1P RIGHT	1coin 5credit				OFF	ON	OFF	OFF
GND	15	GND	1coin 6credit				OFF	ON	OFF	ON
2P SELECT	16	1P SELECT	1coin 7credit				OFF	ON	ON	OFF
	17		2coin 1credit				ON	ON	ON	ON
COIN 2	18	COIN 1	1coin 3credit				ON	OFF	OFF	OFF
GND	19	GND	3coin 5credit				ON	OFF	OFF	ON
	20		3coin 1credit				ON	OFF	ON	OFF
	21		3coin 2credit				ON	OFF	ON	ON
+12V COMMON	22	+12V COMMON	4voin 4credit				ON	ON	OFF	OFF
COUNTER 2	23	COUNTER 1	4coin 1credit				ON	ON	OFF	ON
SPEAKER -	24	SPEAKER +	4coin 3credit				ON	ON	ON	OFF
+12V	25	+12V	FREE PLAY				ON	ON	ON	ON
GND (12V)	26	GND (12V)								
GND	27	GND								
GND	28	GND								
			( DIP SW 2 )							
			1	2	3	4	5	6	7	8
			DIFFICULTY							
			Normal	NOT USE	OFF	OFF				
			Easy		OFF	ON				
			difficult		ON	OFF				
			more difficult		ON	ON				
			BONUS POINT							
			20,000 70,000 Every 70,000				OFF	OFF		
			30,000 80,000 '' 80,000				OFF	ON		
			20,000 80,000				ON	OFF		
			30,000 80,000				ON	ON		
			TABLE TYPE						OFF	
			UP RIGHT TYPE						ON	
			NUMBER OF PLAYER 3							OFF
			4							OFF
			5							ON
			7							ON



dip sw ghosts n goblins

item	description	1	2	3	4	5	6	7	8
difficulty	easy		off	off					
	normal		off	on					
	difficult		on	off					
	very difficult		on	on					

bonus	20.000.70.000	every 70.000			off	off			
points	30.000.80.000	every 80.000			off	on			
	20.000.80.000	only	on		off				
	30.000.80.000	only			on	on			

typ	table						off		
	up right						on		
aaaaaaaaaaaaaaaaaaaaaaaaaaaaaaaa									
number of	3	players				off	off		
players	4	players					off	on	
	5	players					on	off	on
	7	players					on	on	

dip sw 2

item	description	1	2	3	4	5	6	7	8
poriait	normal	off							
	reversal	on							
test mode	normal		off						
	test		on						
sound	with sound			on					
	without sound			off					
coin mode	coin 1 set up				off				
	coin 2 set up				on				
item coin	description	5	6	7	8				
	1 coin-credit	off	off	off	off				
	1 " 2 "	off	off	off	on				
	1 " 3 "	off	off	on	off				
	1 " 4 "	off	off	on	off				
	1 " 5 "	off	on	off	off				
	1 " 6 "	off	on	off	on				
	1 " 7 "	off	on	on	off				
	2 " 1 "	off	on	on	on				
	2 " 2 "	on	off	off	off				
	2 " 5 "	on	off	off	on				
	3 " 1 "	on	off	on	off				
	3 " 2 "	on	off	on	on				
	3 " 4 "	on	on	off	off				
	4 " 1 "	on	on	off	on				
	4 " 3 "	on	on	on	off				
	free play	on	on	on	on				

## DIP SW OF GHOSTS 'N GOBLINS

DIP SW 1A

1	2	3	4	5	6	7	8	FUNCTION	
OFF ON								PICTURE	NORMAL REVERSAL
	OFF ON							TEST MODE	NORMAL TEST MODE
		OFF ON						SOUND DURING DEMO	WITHOUT SOUND WITH SOUND
			OFF ON					COIN MODE	COIN 1 SET UP COIN 2 SET UP
				OFF OFF	OFF OFF	OFF OFF	OFF ON	COIN SET UP	1 COIN 1 CREDIT 1 COIN 2 CREDITS
				OFF OFF	OFF OFF	ON ON	OFF ON		1 COIN 3 CREDITS 1 COIN 4 CREDITS
				OFF OFF	ON ON	OFF OFF	OFF ON	COIN SET UP WILL BE EFFECT BY COIN 4 SW	1 COIN 5 CREDITS 1 COIN 6 CREDITS
				OFF OFF	ON ON	ON ON	OFF ON		1 COIN 7 CREDITS 2 COINS 1 CREDIT
				ON ON	OFF OFF	OFF OFF	OFF ON	FREE PRAY IN CASE OF GAME START WITHOUT CREDIT	2 COINS 3 CREDITS 2 COINS 5 CREDITS
				ON ON	OFF OFF	ON ON	OFF ON		3 COIND 1 CREDIT 3 COINS 2 CREDITS
				ON ON	ON ON	OFF OFF	OFF ON		3 COINS 4 CREDITS 4 COINS 1 CREDIT
				ON ON	ON ON	ON ON	OFF ON		4 COINS 3 CREDITS FREE PLAY

DIP SW 2A

1	2	3	4	5	6	7	8	FUNCTION	
/								UNUSED	
	OFF OFF ON ON	OFF ON OFF ON						DIFFICULTY	NORMAL EASY DIFFICULTY VERY DIFFICULT
			OFF OFF ON ON	OFF ON OFF ON				BONUS POINTS	20,000 POINTS 70,000 EVERY 70,000 POINTS 30,000 POINTS 80,000 EVERY 80,000 POINTS 20,000 POINTS 80,000 ONLY 30,000 POINTS 80,000 ONLY
					OFF ON			TYPE	TABLE TYPE UPRIGHT TYPE
						OFF OFF ON ON	OFF ON OFF ON	NUMBER OF PLAYERS	3 PLAYERS 4 PLAYERS 5 PLAYERS 7 PLAYERS

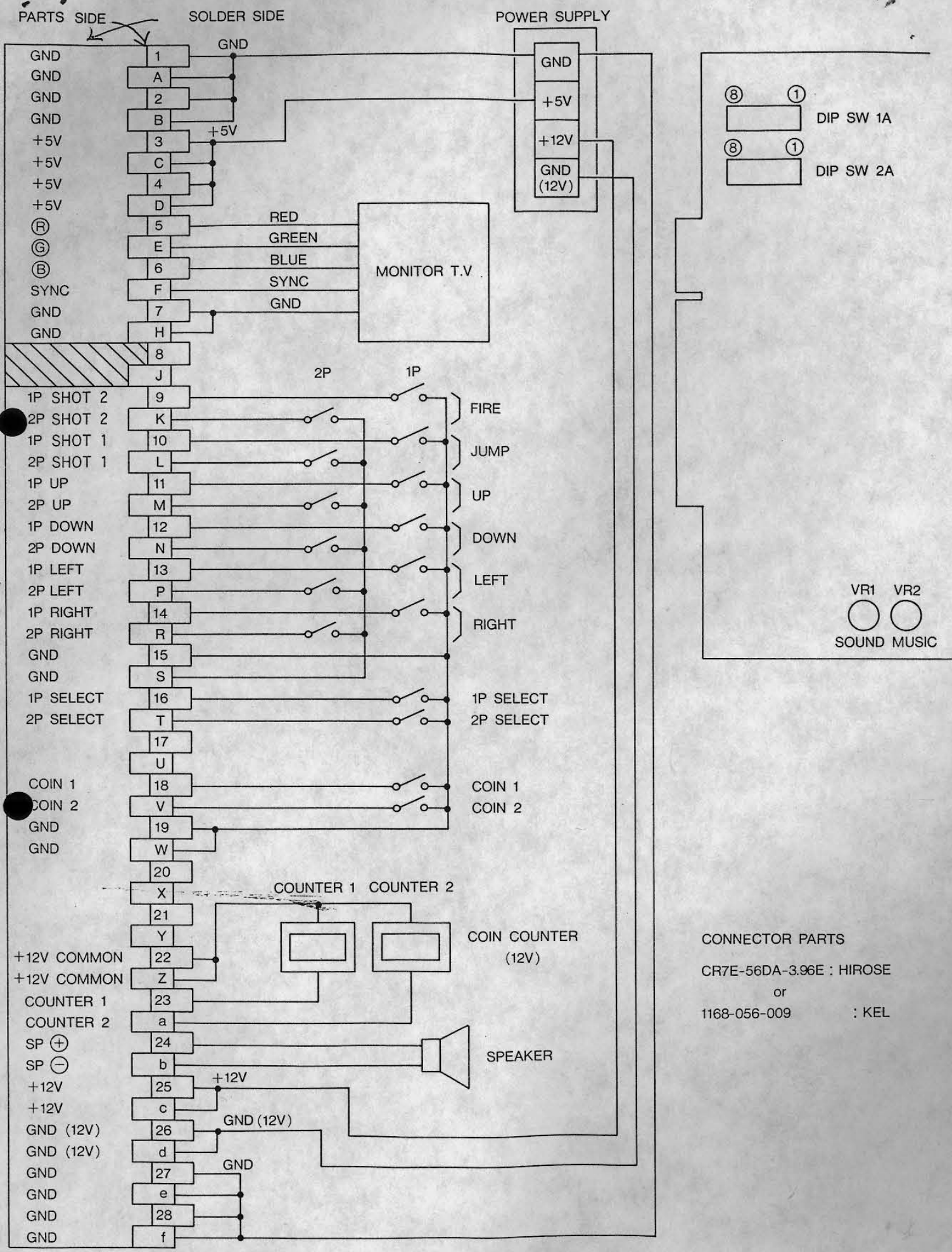

CONNECTOR PARTS  
 CR7E-56DA-3.96E : HIROSE  
 or  
 1168-056-009 : KEL



THE PRINCESS OF A CERTAIN PEACEFUL COUNTRY IS ABDUCTED BY A MESSENGER FROM HADES AND A KNIGHT WHO LOVES THE PRINCESS LEAVES FOR HADES TO RESCUE HER.

HOWEVER, TO RESCUE THE PRINCESS, THE KNIGHT MUST PASS THROUGH SIX GATES GUARDED BY SATAN'S GENERALS TO REACH HADES.

OF COURSE THERE ARE ALSO DEMONS THAT ATTACK THE KNIGHT BETWEEN THE SIX GATES. THE KNIGHT HAS FIVE KINDS OF WEAPONS WHICH HE USES SKILLFULLY TO DESTROY THE ATTACKING DEMONS AND ADVANCE INTO HADES.

THE KNIGHT NEEDS YOUR HELP TO RESCUE THE PRINCESS AND ESCAPE FROM HADES SO TEST YOUR SKILL!

- (1) ZOMBIES WAITING IN CEMETERY
- (2) WEAPONS IN THE ENEMY'S POT
- (3) THE DEMON GENERAL "IKKAKU" WAITING AT THE FIRST GATE
- (4) GIANTS GUARDING THE AREA
- (5) A PARTICULARLY STRONG DEMON
- (6) THE DRAGON AT THE THIRD GATE
- (7) WATCH FOR FLAMES THAT SHOOT UP FROM THE SEA OF FIRE!
- (8) THIS IS THE CRUCIAL MOMENT - CLIMB!

COME AND TRY YOUR HAND AT THIS GAME OF SKILL!

GHOSTS 'N GOBLINS

DESTROY SATAN AND ESCAPE FROM HADES WITH THE PRINCESS.  
HOWEVER, THERE IS A TIME LIMIT.