

羊田面		部品面	
A	GND	1	GND
B	GND	2	GND
C	+5	3	+5
D	+5	4	+5
E	Ⓞ	5	Ⓡ
F	SYNC	6	Ⓟ
G	GND	7	GND
H		8	
I		9	
J		10	
K	SHOT 2	11	SHOT 2
L	SHOT 1	12	SHOT 1
M	UP 1	13	UP 1
N	DOWN 1	14	DOWN 1
O	LEFT 1	15	LEFT 1
P	RIGHT 1	16	RIGHT 1
Q		17	
R		18	
S	GND	19	GND
T	2P SELECT	20	IP SELECT
U	(D5)	21	(D4)
V	COIN 2	22	COIN 1
W	GND	23	GND
X		24	
Y		25	
Z	+12V COMMON	26	+12V COMMON
a	COUNTER 2	27	COUNTER 1
b	SP ⊖	28	SP ⊕
c	+12		+12
d	GND (12V)		GND (12V)
e	GND		GND
f	GND		GND

部品名  
 CR7E - 56DA - 3.96E : HIROSE  
 or  
 1168 - 056 - 009 : KEL

EDGE CONNECTOR			
		85606 - 通資-1-1/2	
60.1129		CAPCOM	

CN - 1

B	A
1	DB0
2	DB1
3	DB2
4	DB3
5	DB4
6	DB5
7	DB6
8	DB7
9	GND
10	
11	GND
12	
SCRWIN	ABO
SCRPO	AB1
SCRCS	AB2
MRDY 2	AB3
SCDO	AB4
SCD1	AB5
SCD 2	AB6
ACL2	AB7
OKOUT	AB8
AKB	AB9
ROB	AB10
BLCNTEN	AB11
WRB	AB12
ROB	AB12

CN - 2

D	C
1	SCR X
2	SCR Z
3	6M
4	4-3H
5	H1
6	H4
7	H16
8	H64
9	H256
10	V1
11	V4
12	V16
13	V64
14	OBJ7
15	OBJ5
16	OBJ3
17	OBJ1
18	HINIT
19	+5V
20	
21	+5V
22	
23	+5V
24	
25	

JOINT CONNECTOR	
85606-運賃-1- 2/2	

CARCOM

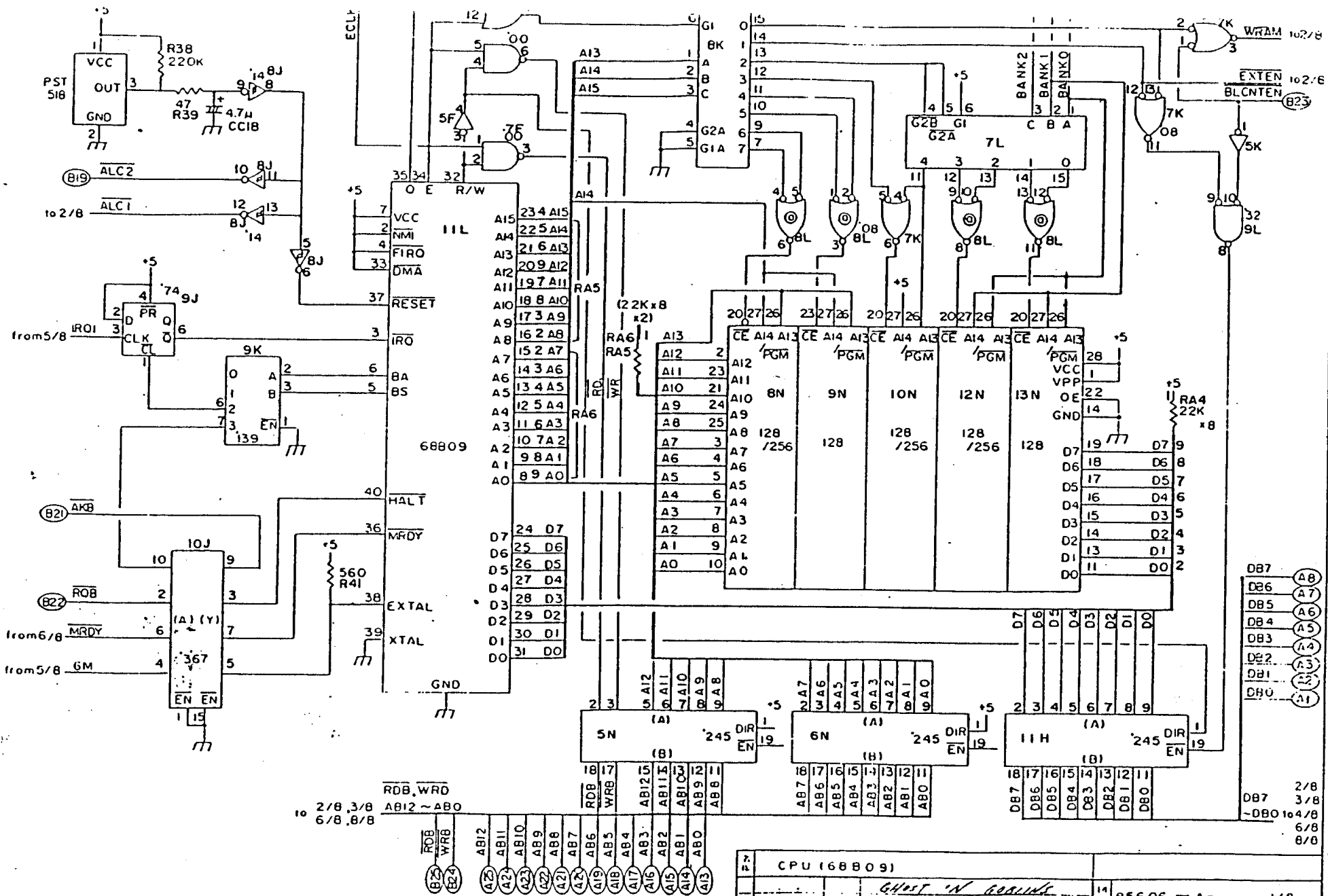

CPU (68B09)			
<i>Ghost 'N' Board</i>			
14	4	85606 - A - 1/8	
<b>CAPCOM</b>			

- DB7 (A8)
- DB6 (A7)
- DB5 (A6)
- DB4 (A5)
- DB3 (A4)
- DB2 (A3)
- DB1 (A2)
- DB0 (A1)

- 2/8
- 3/8
- 6/8
- 8/8

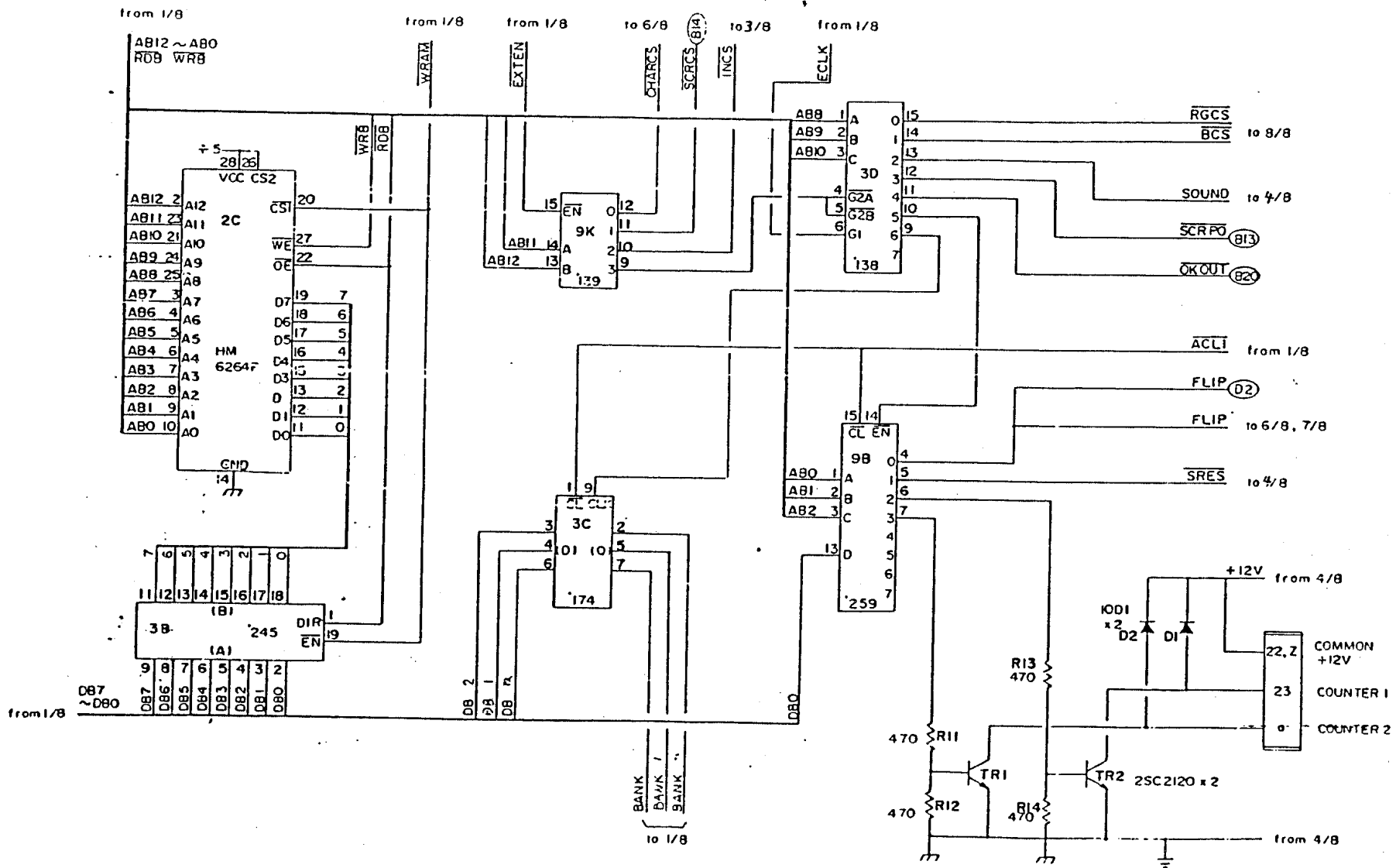

MEMORY MAP / OUT PUT	
	85606 - A - 2 - 2/8
	CAPCOM

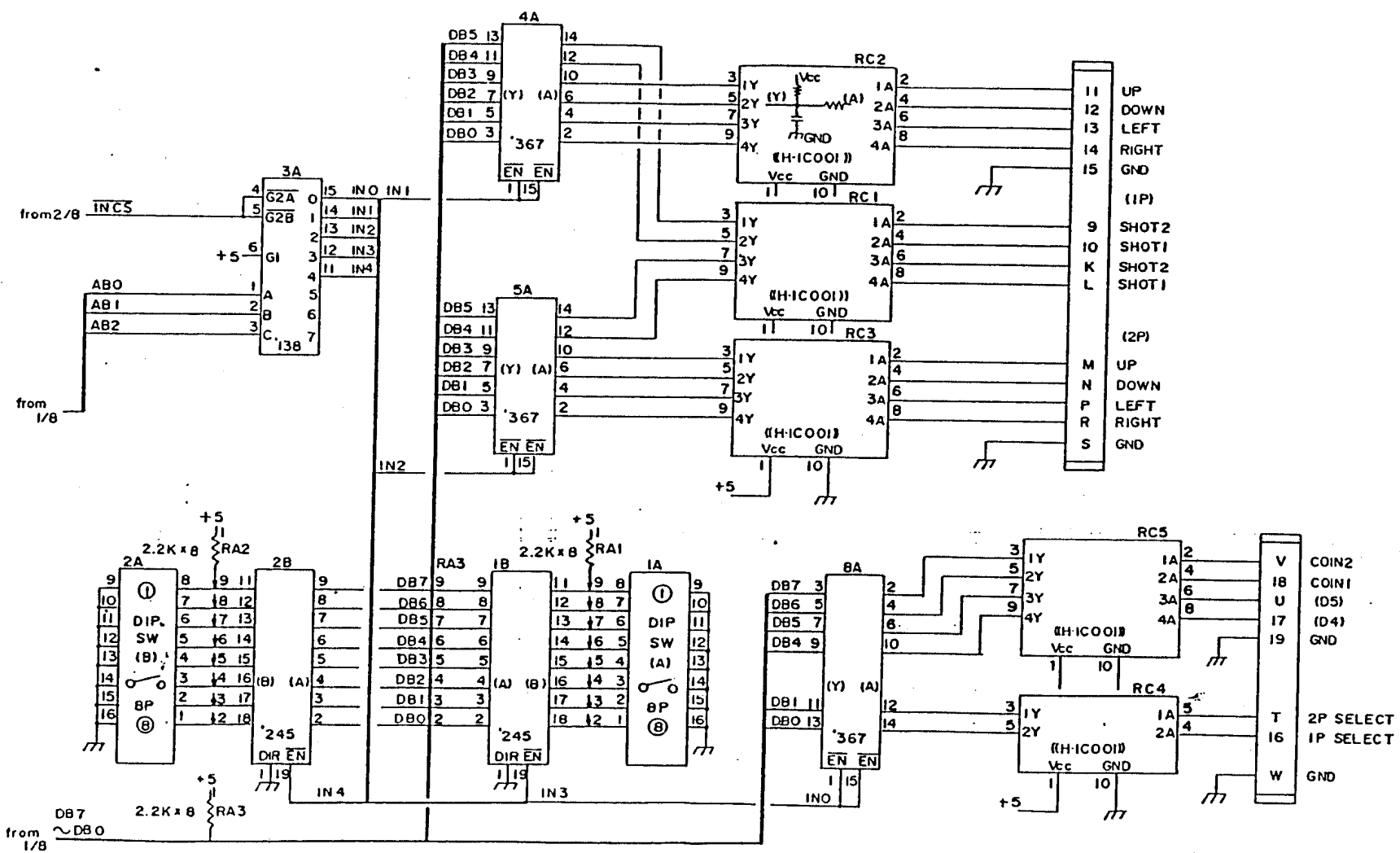

Pin	I/O	PORT
11	UP	
12	DOWN	
13	LEFT	
14	RIGHT	
15	GND	
(1P)		
9	SHOT2	
10	SHOT1	
K	SHOT2	
L	SHOT1	
(2P)		
M	UP	
N	DOWN	
P	LEFT	
R	RIGHT	
S	GND	
V	COIN2	
18	COIN1	
U	(D5)	
17	(D4)	
19	GND	
T	2P SELECT	
16	1P SELECT	
W	GND	

85606 - A-2 - 3/8

CAPCOM

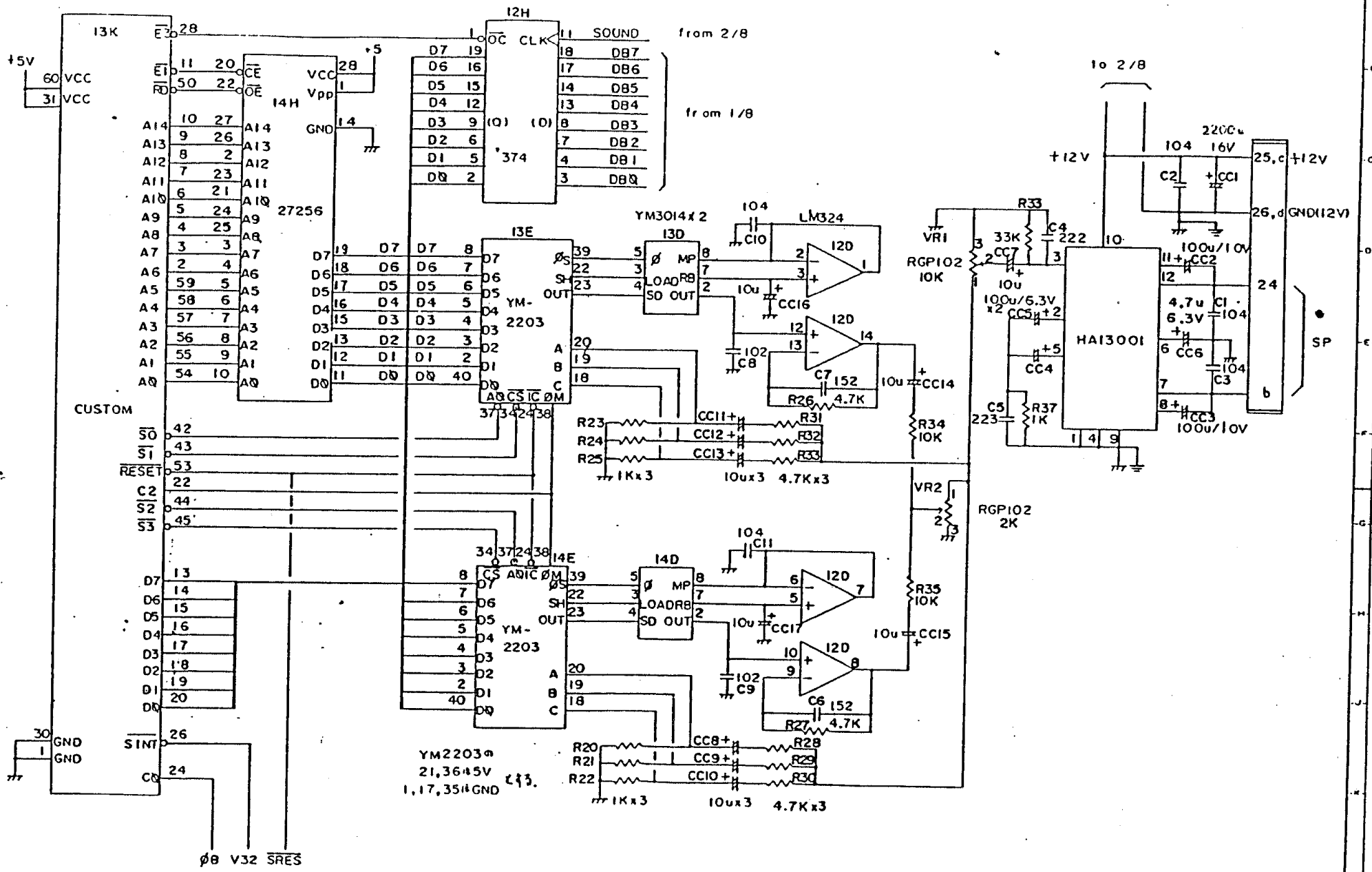

SOUND BY PSG / MAIN AMP			
60.5.22			
85606 -A-2 -4/8			
CAPCOM			

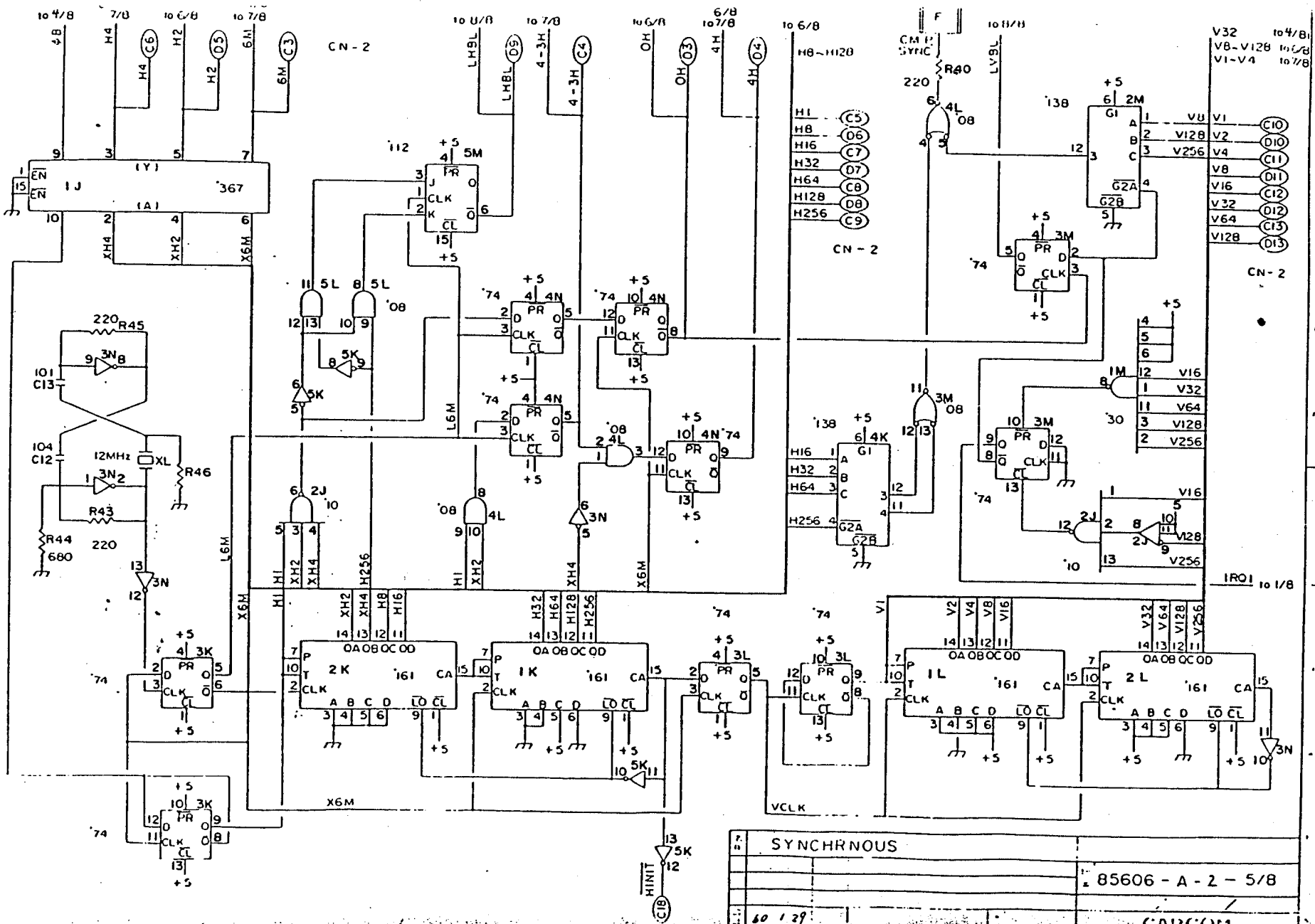

SYNCHRONOUS	
85606 - A - 2 - 5/8	
60 / 29	CAPCOM

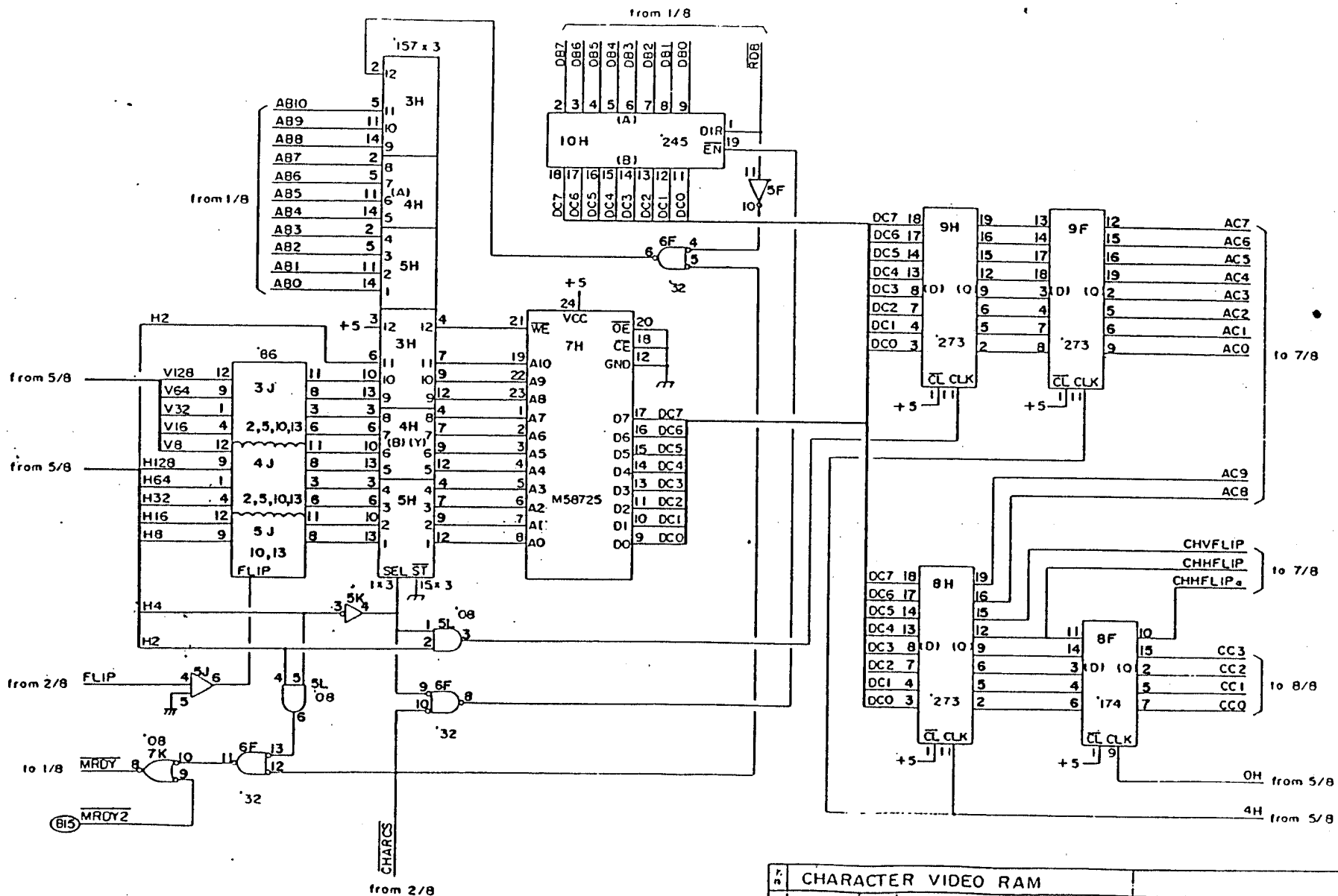

CHARACTER VIDEO RAM	
85606 - A-2- 6/8	
CAPCOM	



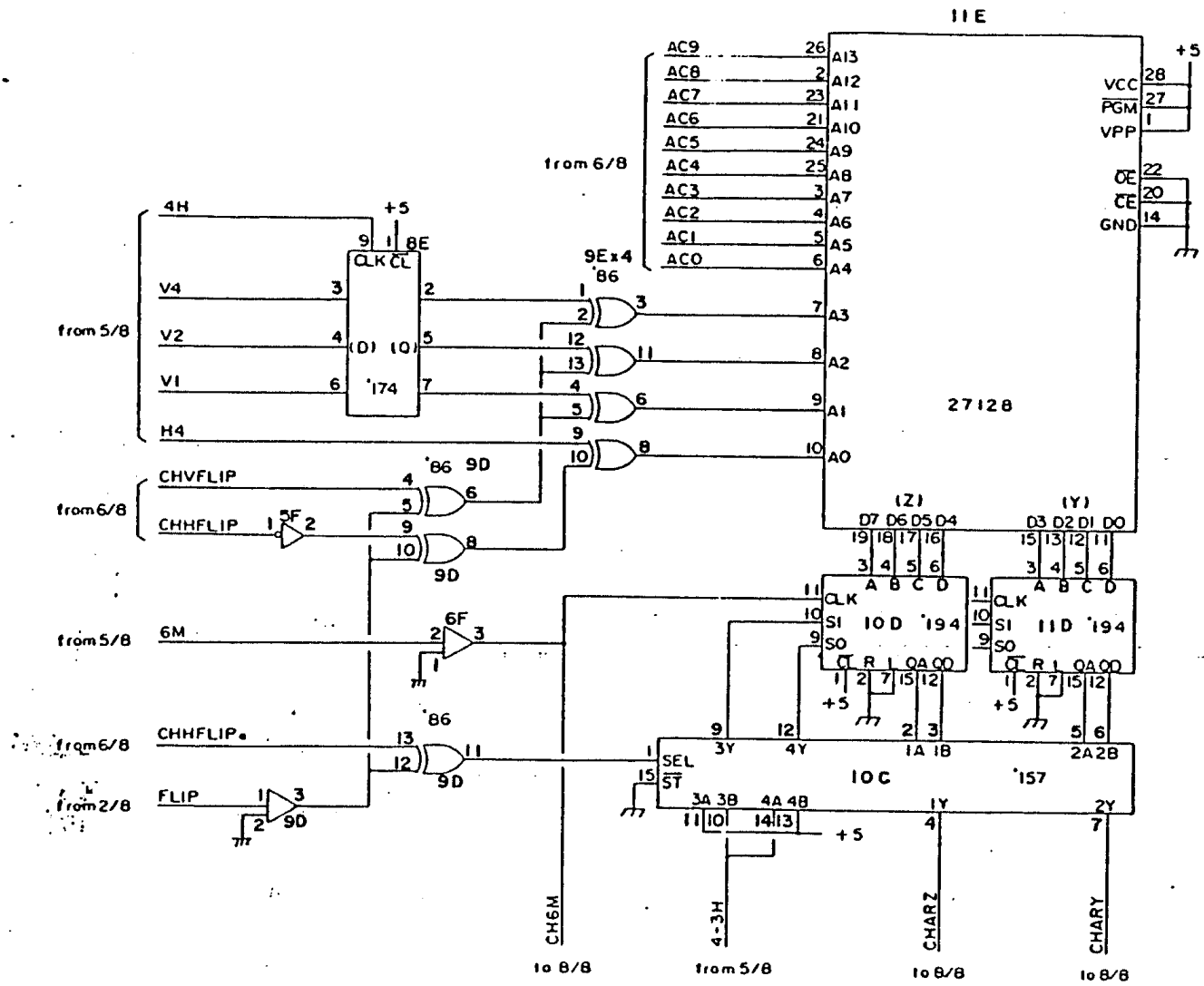

CHARACTER GENERATOR ROM	
14	85606 - A-2 - 7/8
15	/ /

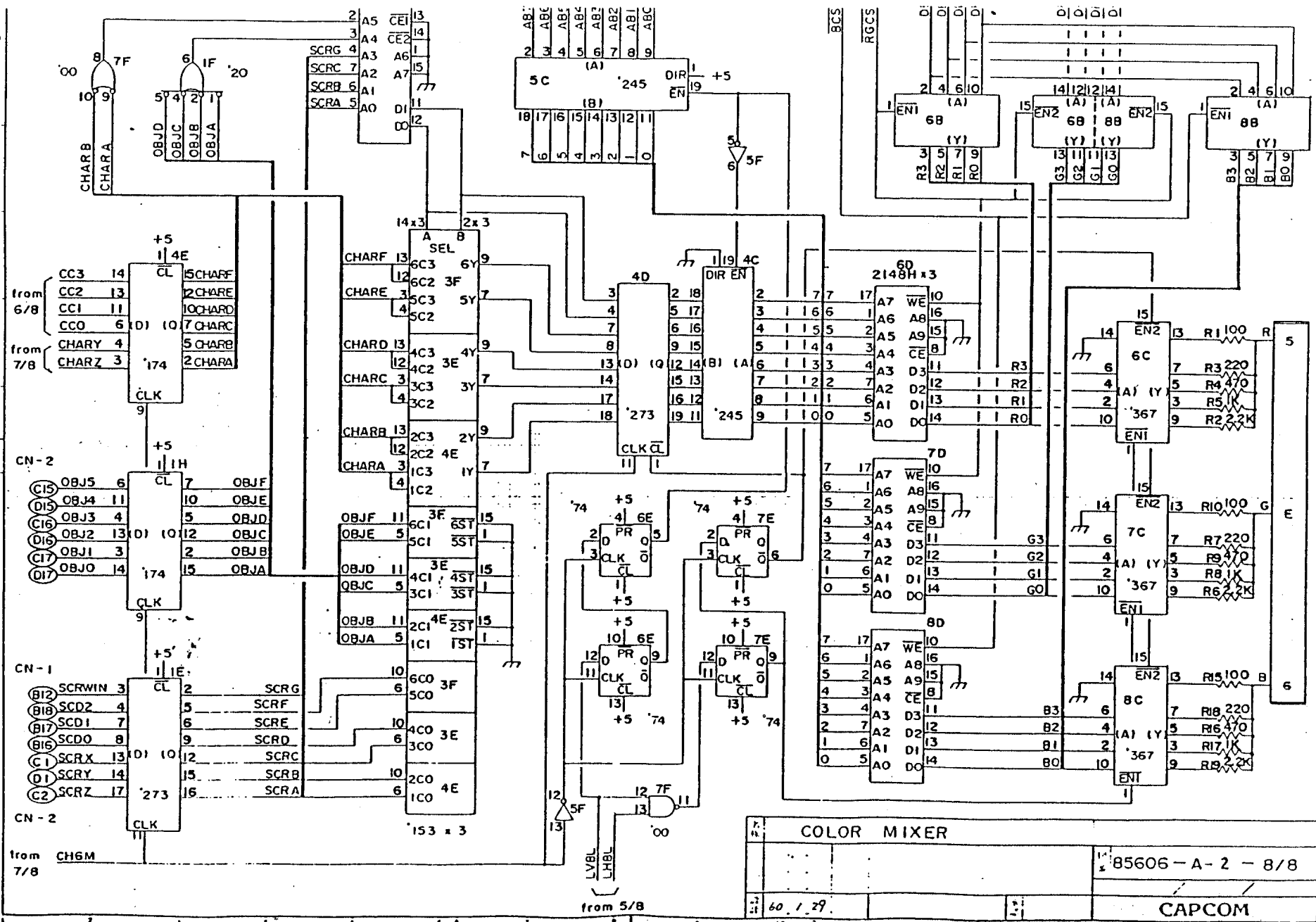

P. N.		COLOR MIXER	
		85606-A-2-8/8	
REV.		60 1 29	
		CAPCOM	

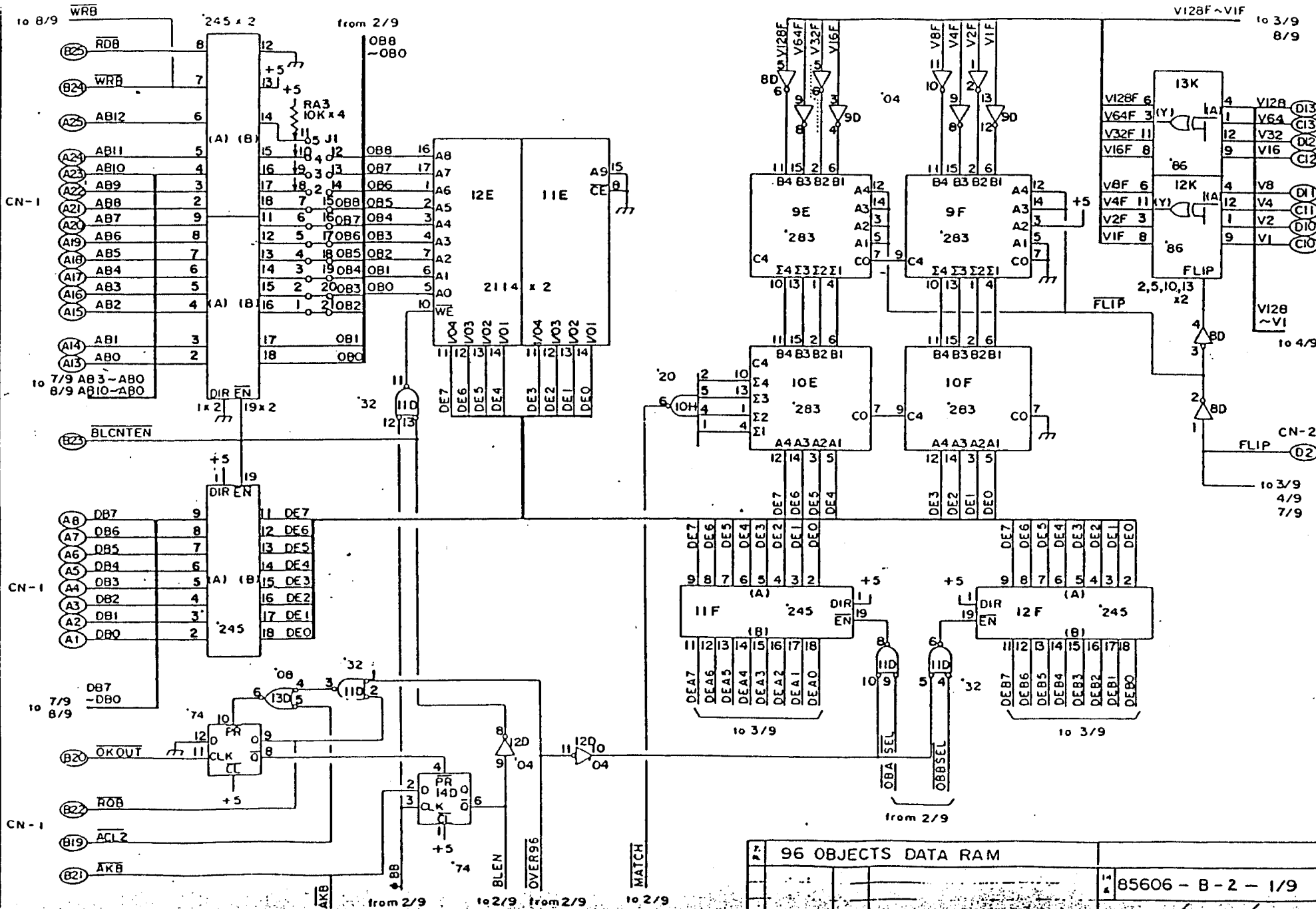

96 OBJECTS DATA RAM	
14	85606 - B - 2 - 1/9

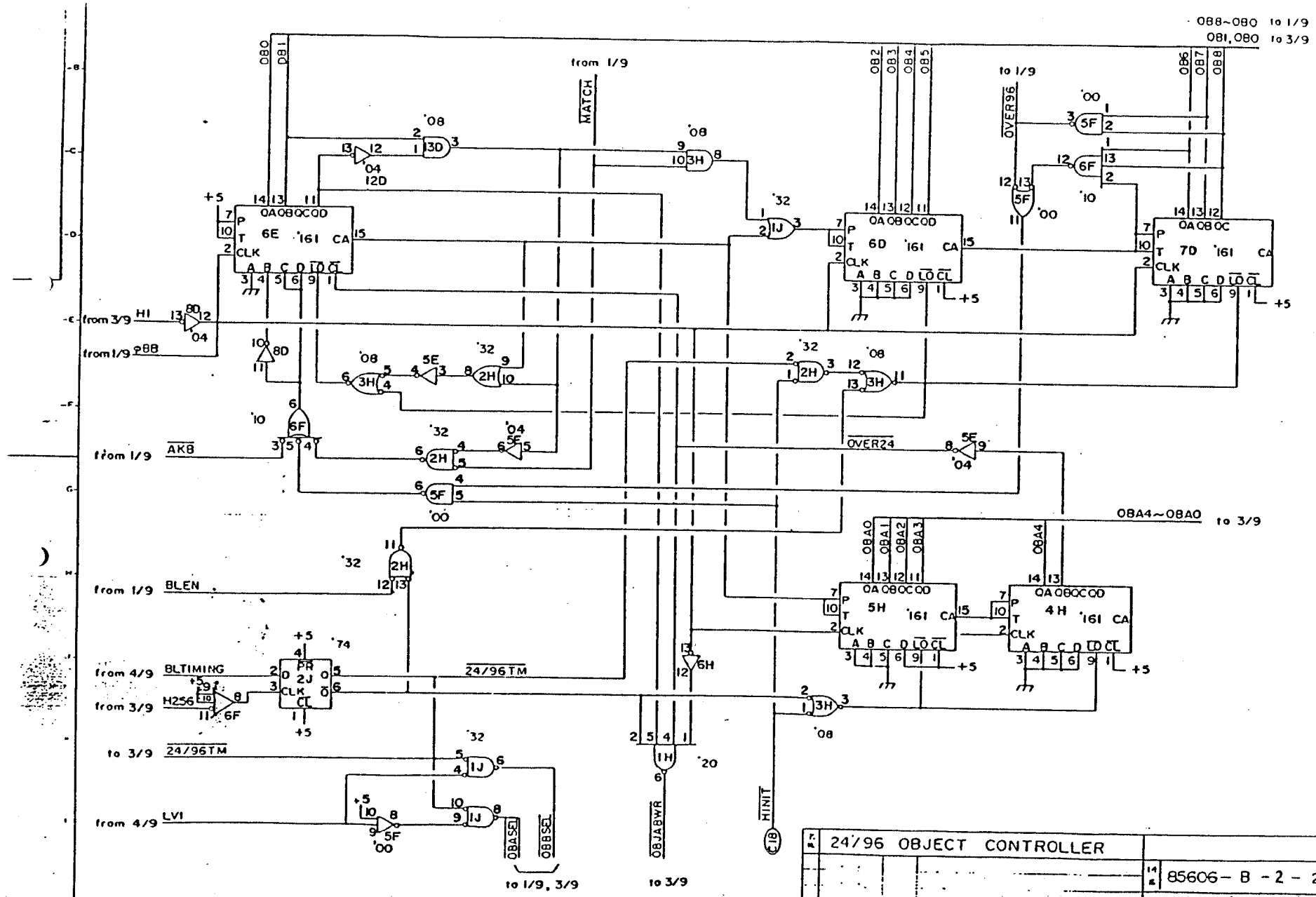

24/96 OBJECT CONTROLLER	
14	85606-B-2-2/9
11	60 1 29
CAPCOM	

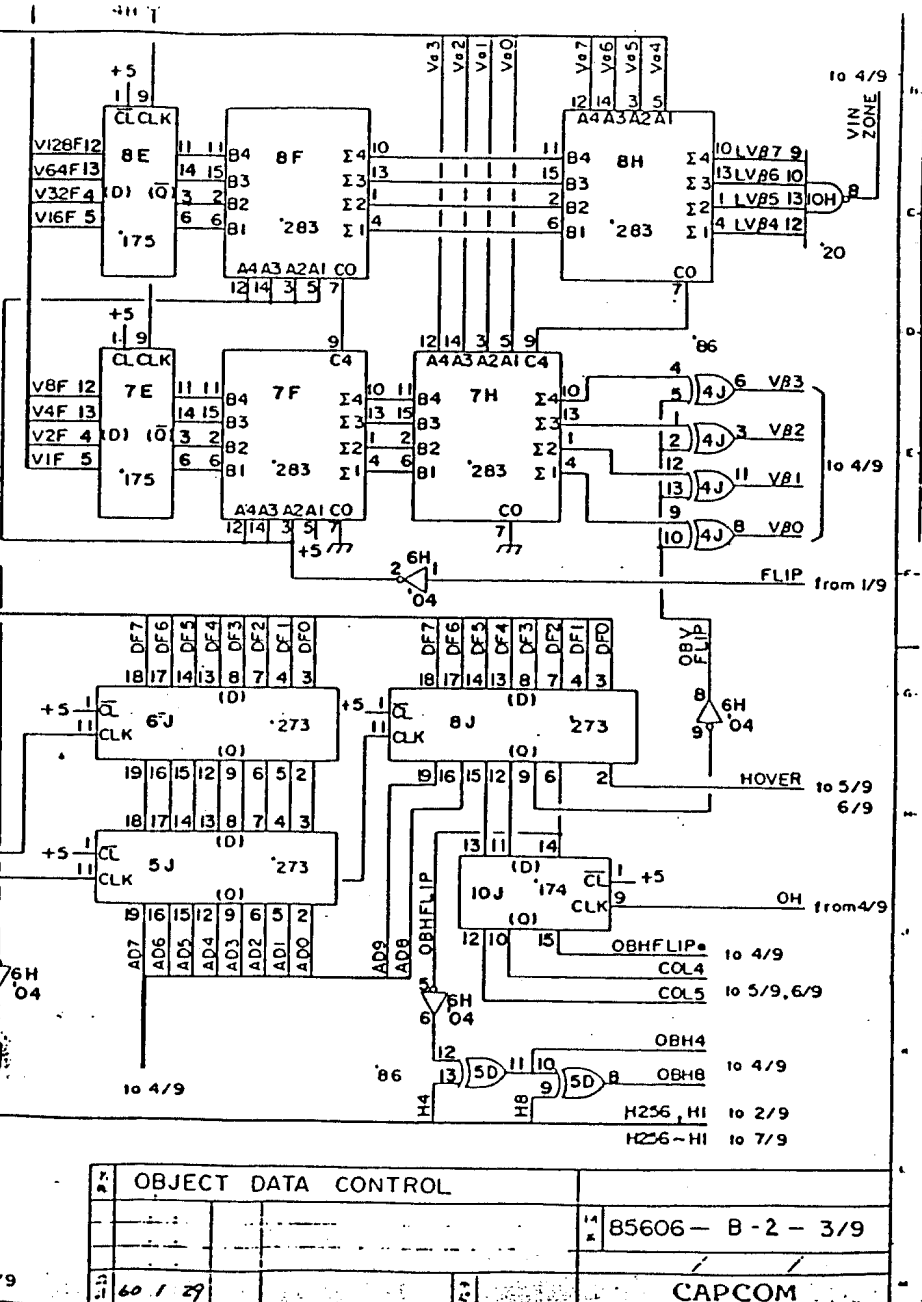
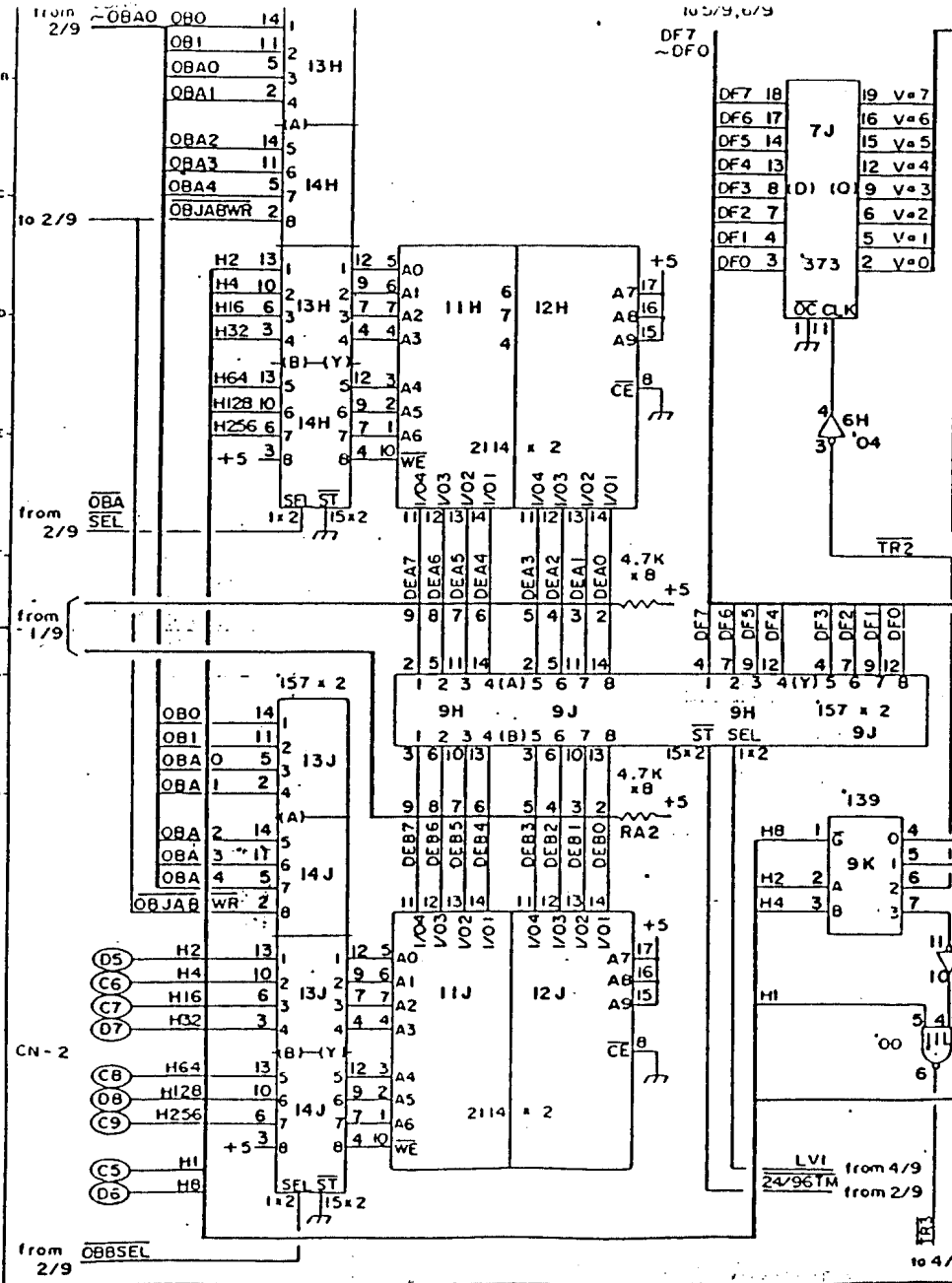

OBJECT DATA CONTROL	
14	B5606 - B-2 - 3/9
21	60 1 29
CAPCOM	

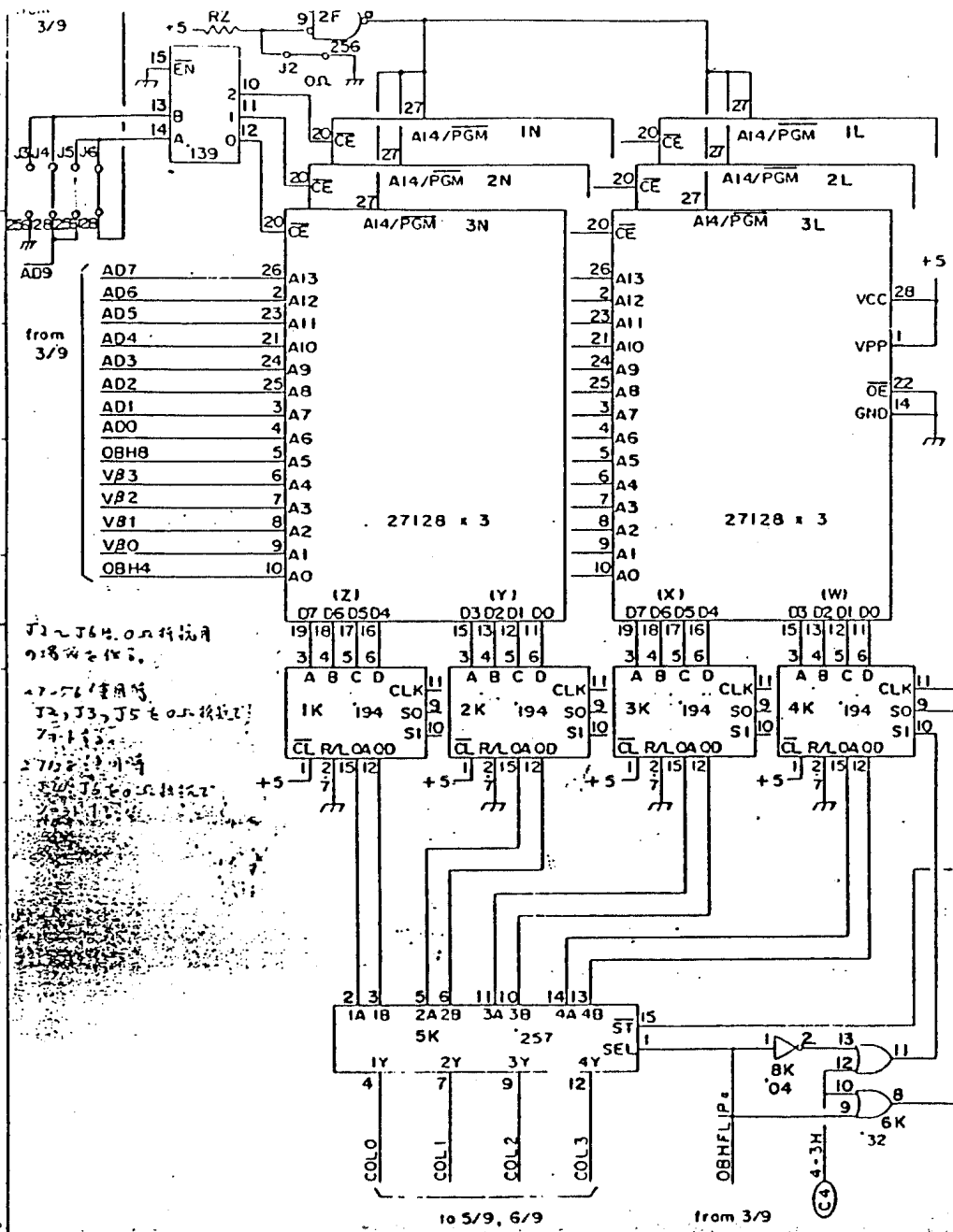

J2, J3, J5 上的插线  
 1K, 2K, 3K, 4K 上的插线  
 7-15  
 257  
 50 15 12

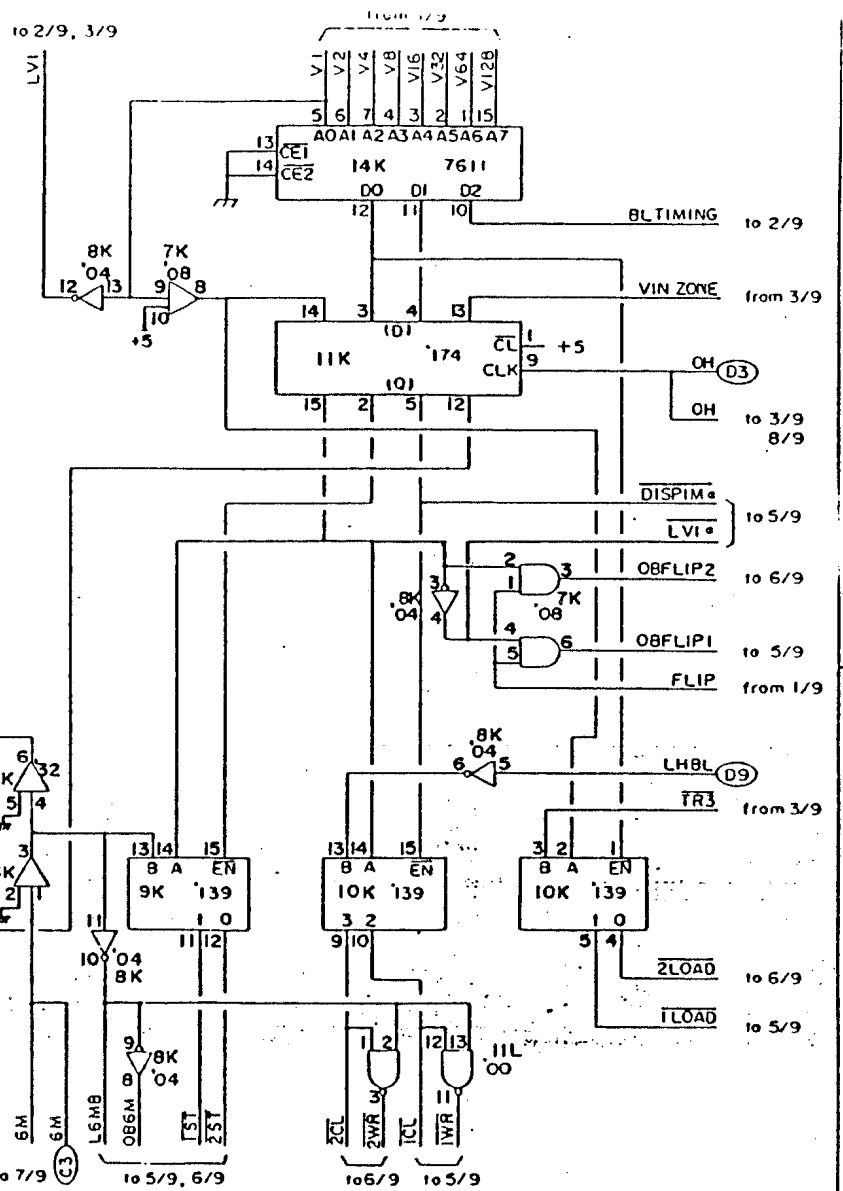

OBJECT ROM		
1	85606 - 8 - 2 - 4/9	
2		
3		
4		
5		
6		
7		
8		
9		
10		
11		
12		
13		
14		
15		
16		
17		
18		
19		
20		
21		
22		
23		
24		
25		
26		
27		
28		
29		
30		
31		
32		
33		
34		
35		
36		
37		
38		
39		
40		
41		
42		
43		
44		
45		
46		
47		
48		
49		
50		
51		
52		
53		
54		
55		
56		
57		
58		
59		
60		
61		
62		
63		
64		
65		
66		
67		
68		
69		
70		
71		
72		
73		
74		
75		
76		
77		
78		
79		
80		
81		
82		
83		
84		
85		
86		
87		
88		
89		
90		
91		
92		
93		
94		
95		
96		
97		
98		
99		
100		

CAPCOM



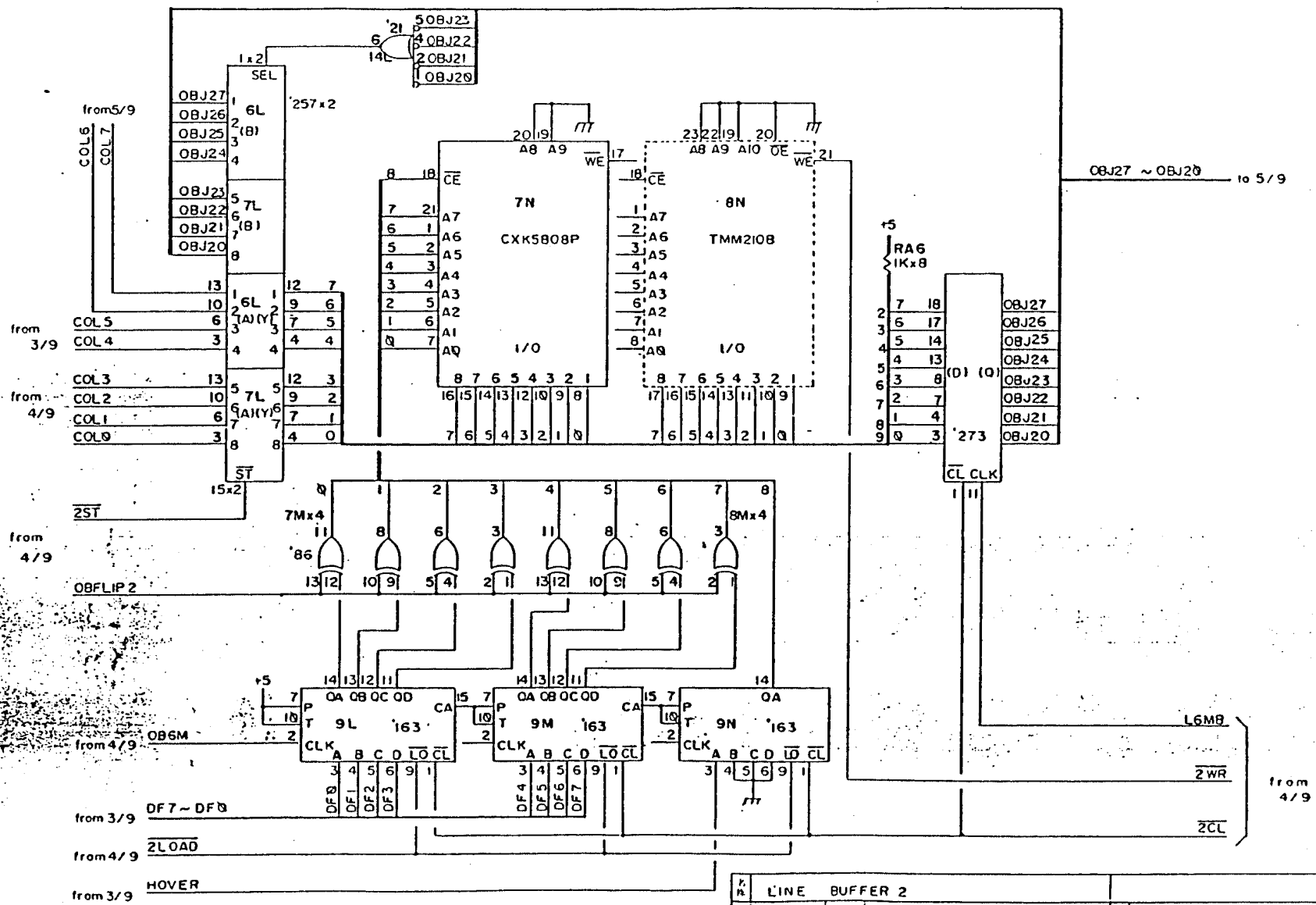

K	A	LINE	BUFFER 2
14	8	85606	8-2-6/9
CAPCOM			



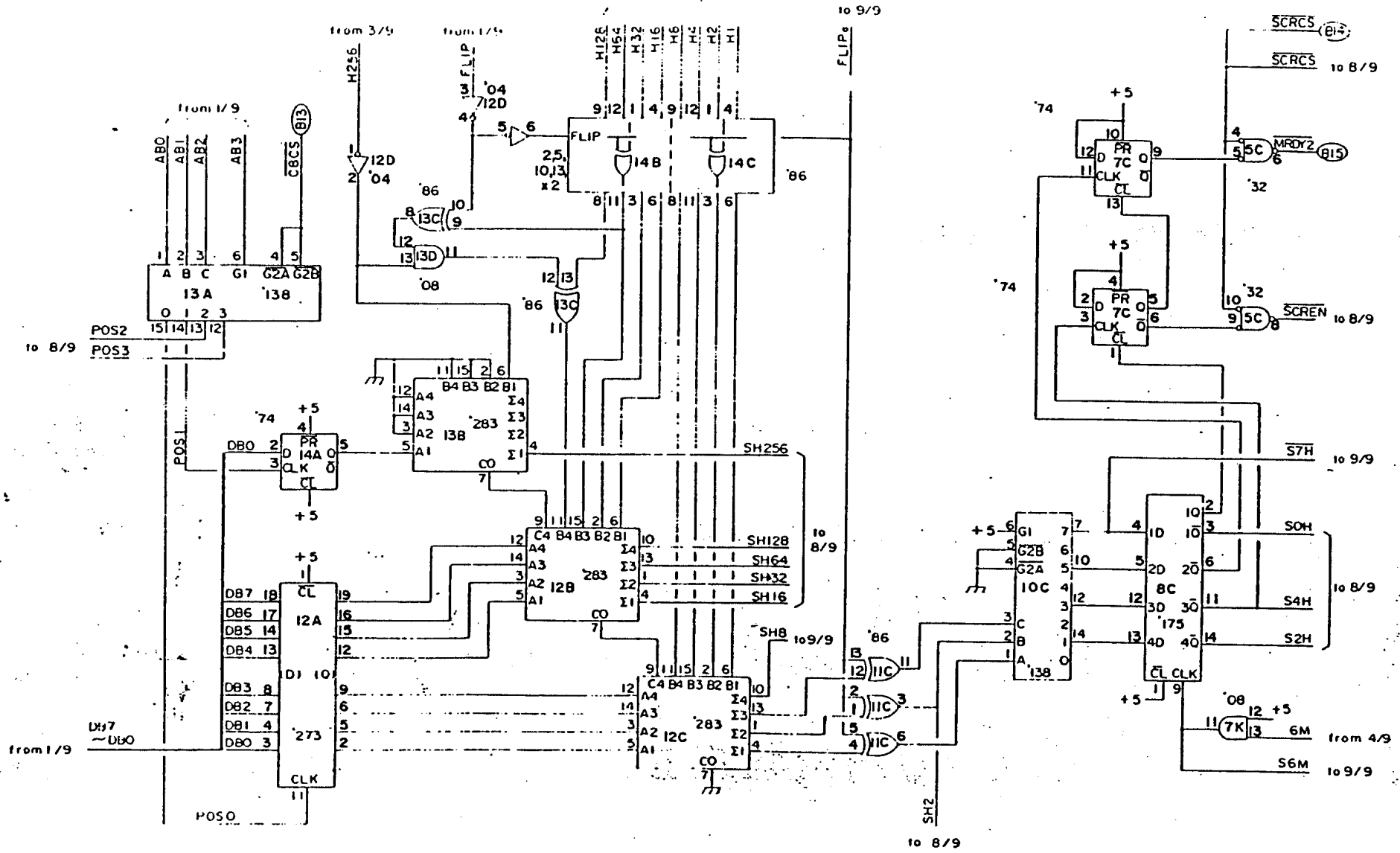

SCROLL H POSITION	
60.129	85606 - B - 2 - 7/9
CAPCOM	

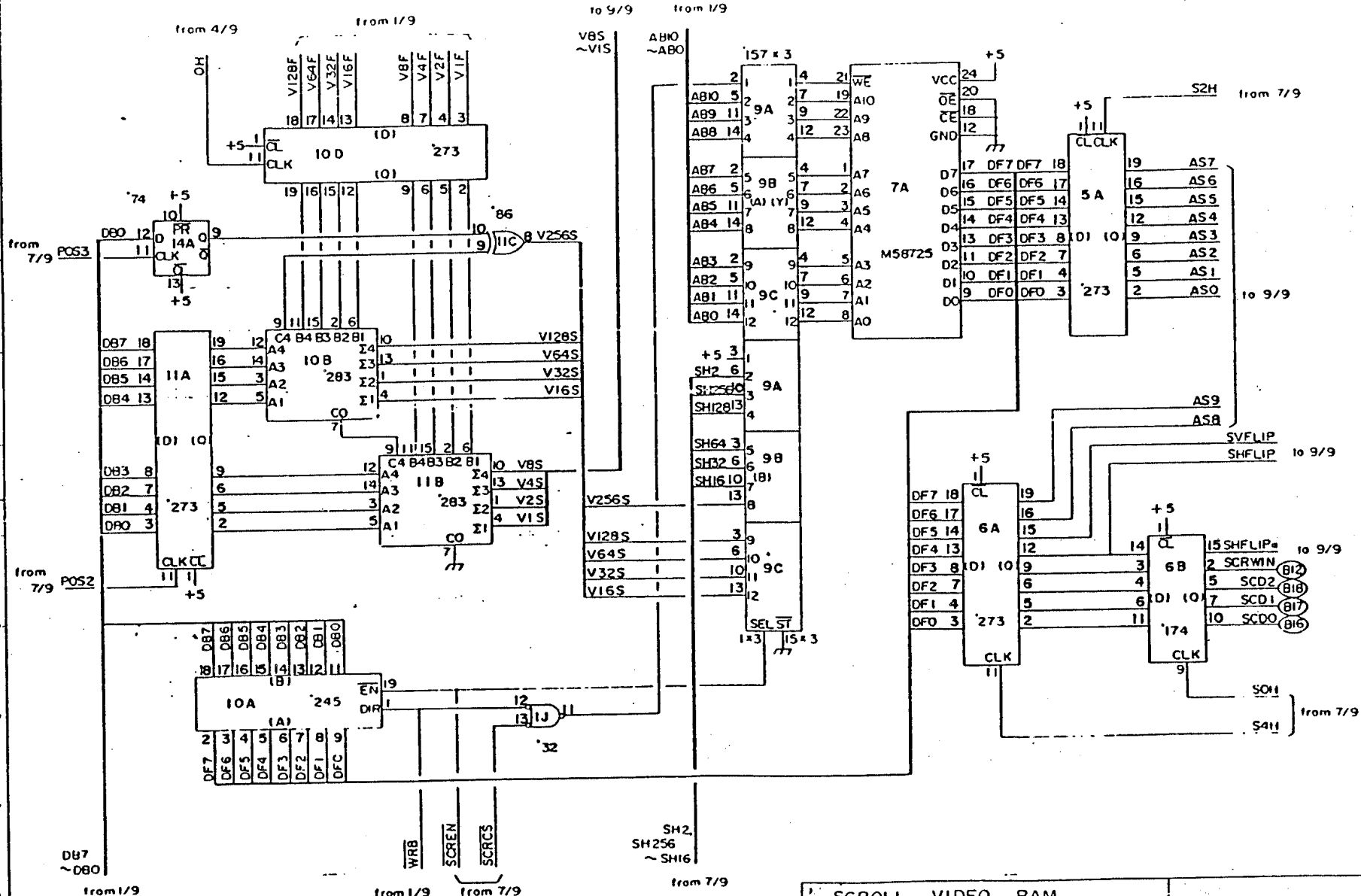

SCROLL VIDEO RAM		
14	85606 - 8 - 2 - 8/9	
		CAPCOM

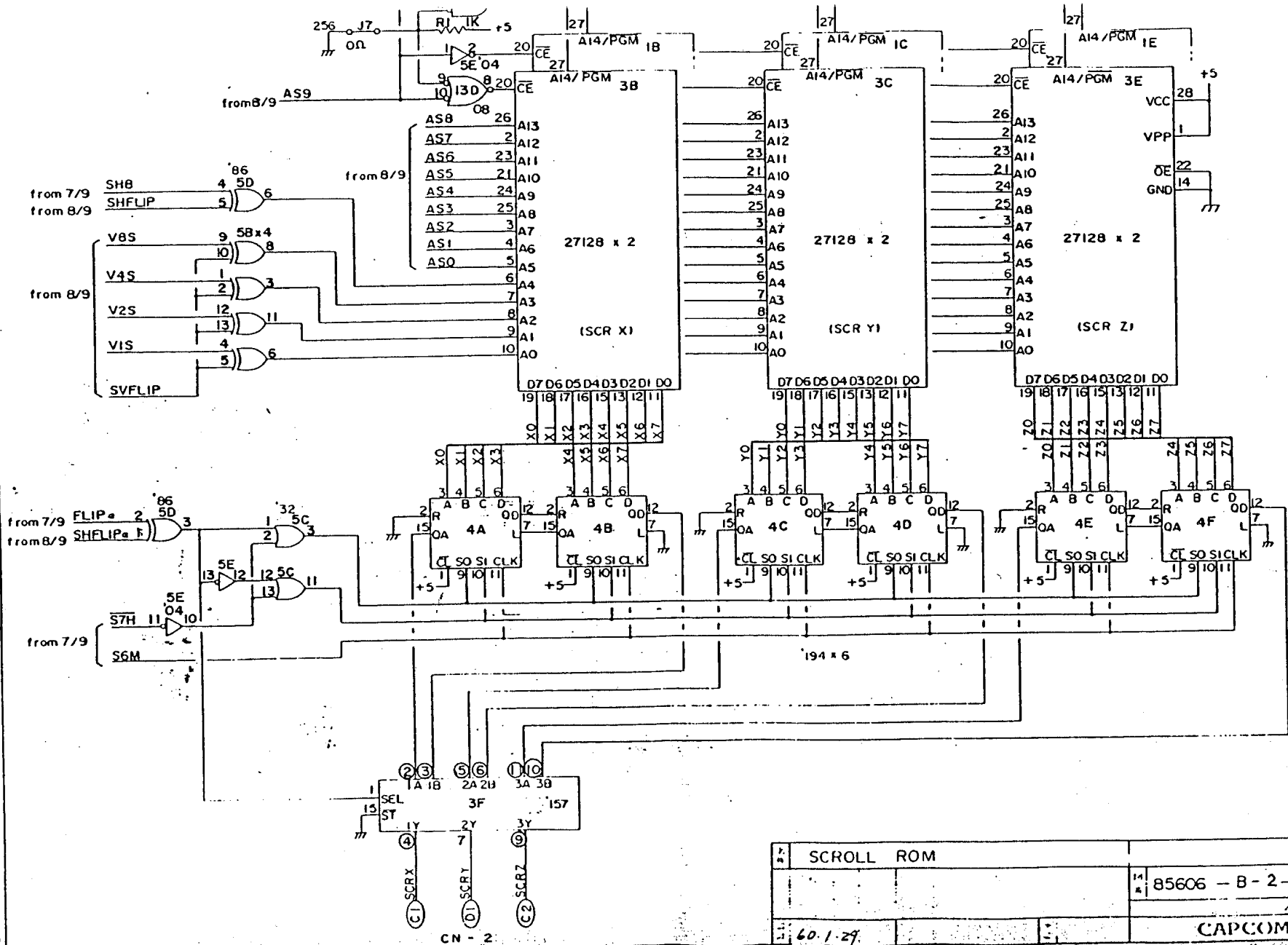

27	SCROLL ROM	
14		85606 - B - 2 - 9/9
11	60.1-29	CAPCOM